



Pump model PA30

MODEL	MAX. POWER kW	PRESSURE bar							CAPACITY l/h
		100	180	200	250	300	400	600	
PA30	15	5.000	2.500	2.500	1.800	1.500	1.100	800	

*Values referring to machines with fixed capacity

**Values referring to products with a max viscosity of 500Cp

TECHNICAL DATA

Plunger number	3
Stroke (mm)	50
Weight (kg)	550
Water consumption (l/h)	90
Lubrication oil quantity (kg)	4
Connection product inlet/outlet	Socket weld flange $\phi e40 \phi i37 / \phi e29 \phi i22$
Max. installed power (kW)	15

Design according to MACHINE DIRECTIVES and the HARMONIZED EUROPEAN STANDARD in force.



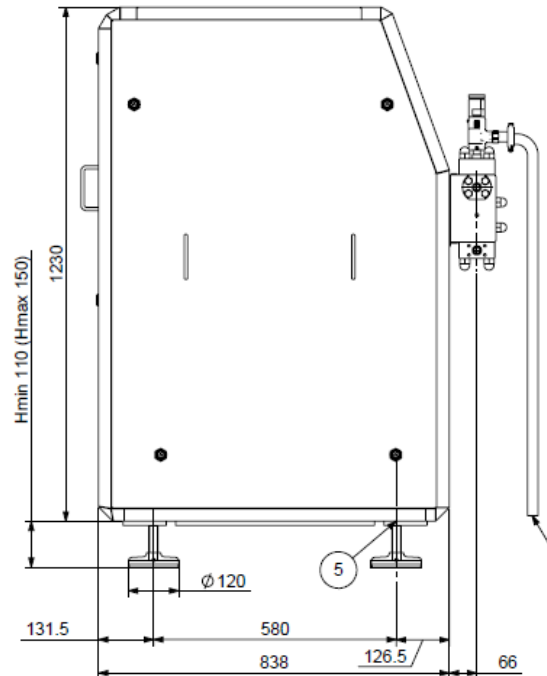
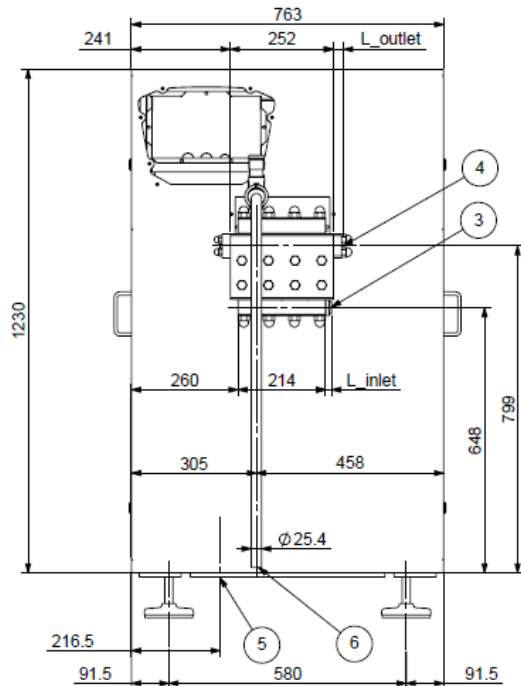

FEATURES

Liquid End: Forged block made from Duplex SAF2205, 3 plungers made from Integral Ceramics, NBR plunger seals

Flat valve seats and poppet/ball valves type made from Stellite™

Digital pressure transmitter 4-20 mA

Overpressure valve, flow switch alarm on water circuit

Drive Unit:

- Splash lubrication system
- Die cast aluminium crankcase
- Nitridized crankshaft
- Direct transmission system with integrated gear reducer with belts and pulleys

Terminal box and control panel for local/remote control

Easy opening panels

Friendly maintenance of the liquid end

MAIN OPTIONS

Aseptic execution

Explosion proof design

Valve seats made from Tungsten Carbide

- Sterile water generator by means of condensed steam generator
- Patent pending sterile water generator by means of microfiltration

Design suitable with: 3A, EHEDG or PHARMA

- Low roughness and electropolished wetted parts
- Certification manual for cGMP

Sound-proof design

Vibration and temperature monitoring and alarm

Pumping plungers availability:

- A316 with HVOF Chromium Carbide jet coat treatment
- A630 with Chromium Carbide coating

Electric power board:

- For Variable capacity
- Remote Control by 4-20 mA signal
- Fully Automatic pressure control by means of PLC

Inlet and outlet connections

- DIN 11851, Tri Clamp, SMS
- High pressure outlet
- Option upon request

