



Pump model PA35

MODEL	MAX. POWER kW	PRESSURE bar							CAPACITY l/h
		100	180	200	250	300	400	600	
PA35	110	35.000	20.000	18.000	15.000	11.500	9.000	5.500	

*Values referring to machines with fixed capacity

**Values referring to products with a max viscosity of 500Cp

TECHNICAL DATA

Plunger number	3
Stroke (mm)	130
Weight (kg)	4.200
Water consumption (l/h)	120
Lubrication oil quantity (kg)	50
Connection product inlet/outlet	Flange to weld $\varnothing e115 \varnothing i110 / \varnothing e52 \varnothing i46$
Max. installed power (kW)	110

Design according to MACHINE DIRECTIVES and the HARMONIZED EUROPEAN STANDARD in force.



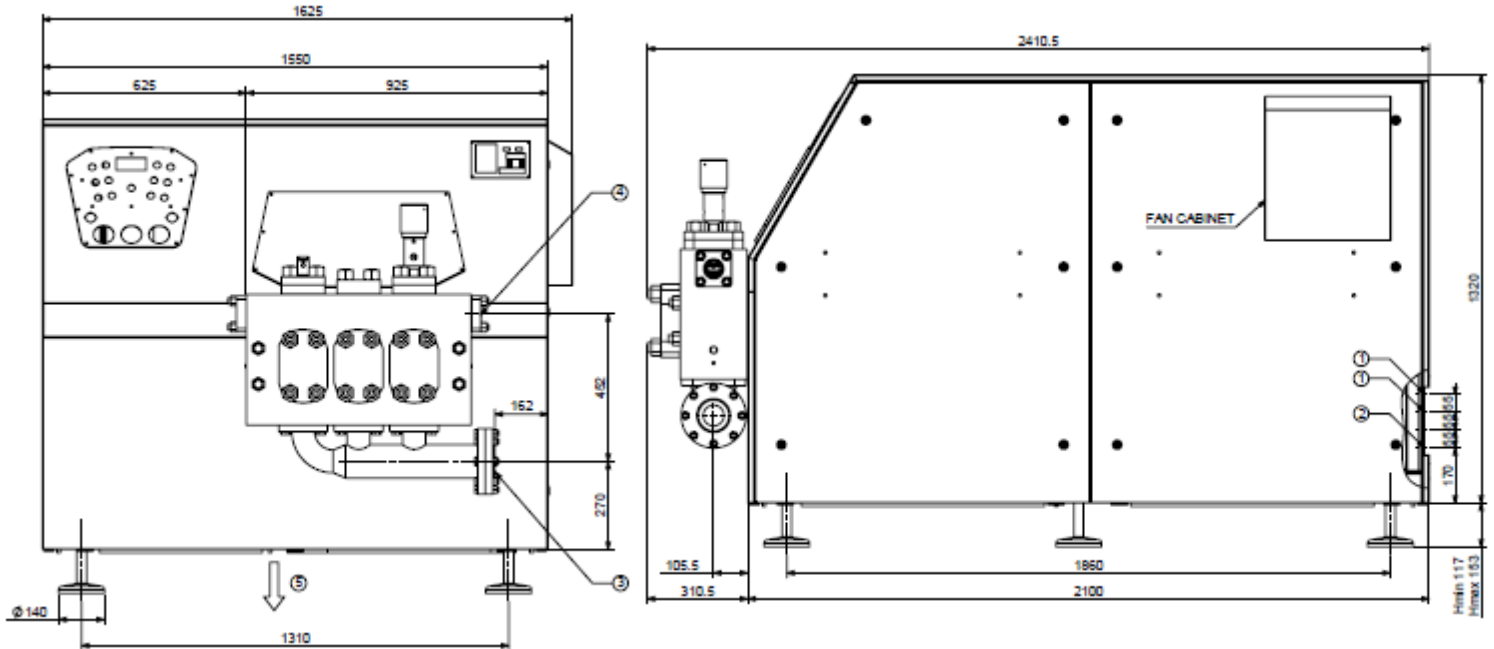

FEATURES

Liquid End: Forged block made from Duplex SAF2205, Self-alignment patented system, 3 plungers made from A630 with Chromium Carbide coating

Conical valve seat and poppet/ball valves made from Stellite™

Drive unit:

- Splash lubrication system
- Die cast iron crankcase
- Nitridized crankshaft
- Direct transmission system with internal gear reducer with belts and pulleys

Overpressure valve, flow switch alarm on water circuit

Digital pressure transmitter 4-20 mA with ceramic membrane

Terminal box and control panel for local/remote control

Easy opening panels

Friendly maintenance of the liquid end

MAIN OPTIONS

Solvent resistant configuration installing special seals

Aseptic execution

Valve seats made from Tungsten Carbide

- Sterile water generator by means of condensed steam generator
- Patent pending sterile water generator by means of microfiltration

Design suitable with: 3A, EHEDG or PHARMA

- Low roughness and electropolishing of product wetted parts
- Certification manual for cGMP

Sound-proof design

Vibration and temperature monitoring and alarm

Pumping plungers availability:

- A316 with HVOF Chromium Carbide jet coat treatment
- Ceramics

Electric power board:

- For Variable capacity
- Remote Control by 4-20 mA signal
- Fully Automatic pressure control by means of PLC

Inlet and outlet connections:

- DIN 11851, Tri-clamp, SMS
- High pressure outlet
- Option upon request

Explosion proof design

***Technical specifications are not mandatory and subject to change without notice.

REV-09/24-EN

